

Supplement 1

Outliers

We excluded the datapoints (all measures of the timepoint) of all participants with measures deviating from the mean by 3SD for our core variables (LSNS-score, adjusted hippocampal volume, cognitive functions). In case of TICS-score deviations by 3SD we replaced the values with “NA” and hence did not include them in mediation analyses.

Considering confounders, highly implausible values (± 4 SD) for CES-D-score or BMI were treated as missing datapoints and we replaced them with values imputed according to our imputation plans listed below in order not to overly reduce the sample size.

All outlier analyses were conducted separately for baseline and follow-up measurements.

Imputation

The data on the control variables education, BMI, diabetes, hypertension, age, and gender were complete or mostly complete. Henceforth, we could impute missing datapoints without inducing severe bias by using the sample mean for continuous variables or values drawn from a distribution determined by the existing data for categorical variables.

However, CES-D-scores were an exception amongst our control variables because the questionnaires often missed a single or a few items. As suggested by Bono et al., we imputed up to 4 missing items per participant using the person mean(1). Similarly, we imputed up to one item in the LSNS and up to six items in the TICS using the mean.

If results from one of the cognitive tests required to calculate a composite score for a cognitive function was missing, we calculated the score based on the average performance in the remainder of available tests contributing to the composite score, if at least two tests were available.

Families of tests

The LMEs with hippocampal volume and the cognitive functions as dependent variables form one large family except for models regressing on the interaction of baseline LSNS and change in LSNS. In each family, we separately corrected model one and model two analyses resulting in two families of twelve tests. Additionally, we FDR-corrected each individual whole brain analysis using the sided two-stage adaptive FDR-correction in the FreeSurfer-toolbox.(66) All other analyses and the whole brain analyses were considered to be exploratory and must be evaluated as such.

Simulation Studies

Although it is sometimes claimed that Bayesian Statistics do not require any multiplicity control(2), we do not believe that this is the case in our study. A truly Bayesian approach would require researchers to adjust the priors to all other tests with non-independent hypotheses or datasets(3). This is hardly feasible and hence, in practice, Bayesian statistics are usually employed without taking all dependencies into account and their results are measured against thresholds similar to those of frequentist statistics. Sup. 20 shows how this results in an increasing familywise error rate (FWER) with an increasing number of tests in both Bayesian and frequentist statistics using an example from Keyzers et al.(4). De Jong has provided a solution for this problem for ANOVAs that has been implemented in the JASP

software(5) but there is still a great lack of available tools for researchers using other statistical methods. Henceforth, we decided to conduct a simulation study to find a Bayes Factor threshold adjustment that should control our FWER similar to α -adjustments in frequentist statistics.

To find the expected number of false positives for a given number of tests and threshold, we replaced the variables for baseline social isolation and change in social isolation with random normally distributed values with the same SD and kept the original dataset otherwise untouched. Then we calculated our 24 LMEs belonging to the families of tests with the modified dataset and repeated this process 42 times. At a BF threshold of 3, 14 of the 1008 tests were false positives and 881 were detected as true negatives. Sup. 21 shows a histogram of the resulting Bayes Factors. The study suggests that for the family size of twelve tests in our study a threshold of about 10.75 would ensure a FWER below 5%. Sup. 22 gives an overview of the false positives and FWERs.

Furthermore, we wanted to see how this threshold adjustment would affect the power of our study. For this simulation study we generated a dataset that closely resembles the actual dataset but has different regression coefficients for baseline social isolation and change in social isolation. Instead of the actual coefficients we set the effect size per point on the LSNS to 0.1, 0.2 or 0.5 years of baseline age. We simulated a dataset and calculated a Bayes Factor for each model and each effect size. As we only calculated the LMEs without interaction terms for reasons of simplicity this resulted in a number of 48 Bayes Factors from simulated data for each of our 13 runs totalling 624 tests. While our power for the smallest effect sizes was generally small (<10%), it was 85.6% for baseline social isolation with an effect size of half a year of baseline age. Increasing the threshold to 10.75 would not substantially decrease it (81.7%). Sups. 18 and 19 provide an overview of the percentages of false negatives and true positives using the thresholds 3 and 10.75.

Deviations from our Preregistration

For the most part, we stuck closely to our preregistered plan in this study but departed from it at some points for different reasons.

We used the function `qvalue` instead of `p.adjust` for the FDR correction for the simple reason that it provides us with a more comprehensive output. As we set the argument `pi` to 1, `qvalue` is equivalent to the classic procedure(6).

We originally intended to first perform a full-null model comparison using an anova and only follow this up with the function `drop1` in case of a significant value for the respective predictor of interest. Our intention was to avoid any multiplicity problems due to testing all predictors. Using the `scope` argument of `drop1` solved the problem more parsimoniously.

Our plan to exclude participants with two or more lesions in their MRI was the result of an internal equivocation regarding the meaning of an abbreviation. We excluded participants based on the type of lesions but not based on lesion count.

Lastly, we changed from the term `sex` to `gender` as it seems more appropriate.

Reflexivity

Reflexivity, a sensitivity to and acknowledgment of the ways in which scientists shape the collected data and research findings, is an established hallmark of scientific rigour in

qualitative research(7,8). The challenges addressed by reflexivity are perhaps more pronounced in but by no means exclusive to qualitative studies. Nevertheless, (at least in an openly conducted form) it is largely absent from quantitative studies(9). Methodological reforms in quantitative research like preregistrations and registered reports(10,11) are valuable tools to limit the researchers' potential to make data fit their prior assumptions but their scope is limited. They do not address some of the most fundamental issues in epidemiology: Which analogies are used to make sense of the data, which questions are being raised and answered and which theories are chosen to explain phenomena(12)? Disclosing personal characteristics, researchers' values and positionality relative to the object of research(13) thus helps readers assess a study and its findings more thoroughly. Additionally, an external evaluation of the presence and prevalence of non-empirical decision vectors(14) in a field of research can be greatly facilitated. Furthermore, as Stephen J. Gould has put it: "It is dangerous for a scholar even to imagine that he might attain complete neutrality, for then one stops being vigilant about personal preferences and their influences – and then one truly falls victim to the dictates of prejudice."(15)

Henceforth, I, as the first author, want to expand this study by a brief reflection on influences that might have played a role in the formation of this study. I am a medical doctoral student with no prior experience in research and conducted this study as the centrepiece of my planned dissertation. Thus, I entered this project with little prior knowledge. I believe that this both made me more flexible and restricted in my choices. On the one hand I was not dedicated to any specific research programme or topic, but on the other hand my reliance on the advice and support from more senior researchers made me emulate their work and methods in many aspects. Further, my worldview has probably made me tend to epidemiological theories (social epidemiology, eco-social theory)(16,17) broader than the study of lifestyle-factors and hence made me choose social isolation as my research topic. A further characteristic that might be of interest to readers, is that during the course of the research, two of my relatives struggled with dementia. Ultimately, this reflexivity is inherently limited, as the use of secondary data precludes me from reflecting on the pivotal processes of data acquisition and participant recruitment.

Supplement 2

Directed acyclic graphs demonstrating the theoretical underpinnings of model 1 and 2.

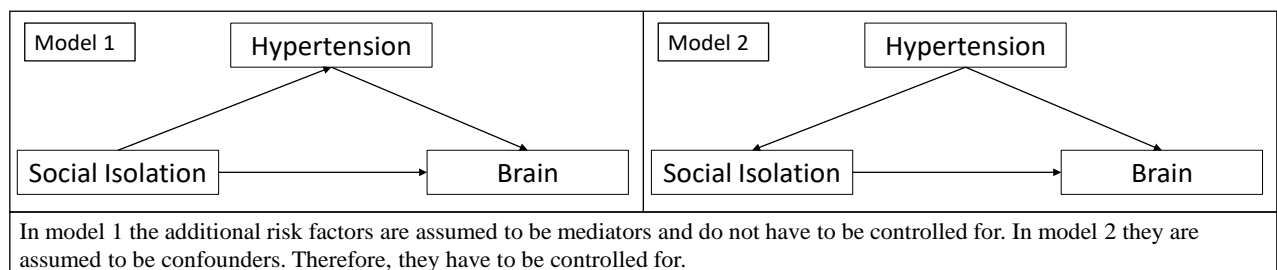

Supplement 3

Simplified plot of the bivariate latent change score models

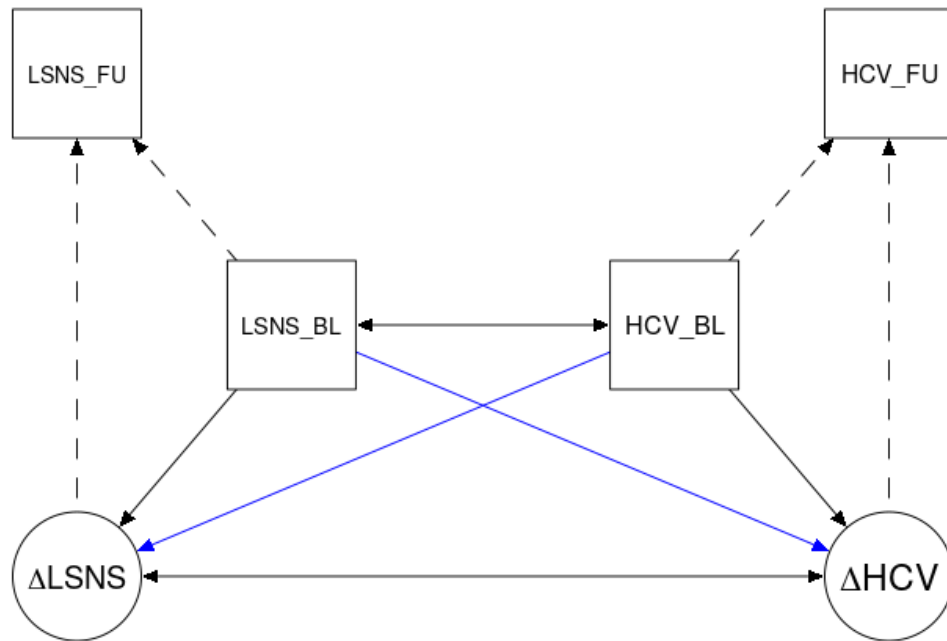

LSNS, Lubben Social Network Scale; HCV, hippocampal volume; BL, baseline; FU, follow-up; Δ , change in

The blue arrows show our paths of interest.

Supplement 4

Fit indices of mediation analyses of model 1

fit index	311	ok?	411a	ok?	411b	ok?	411c	ok?
chisq	4.987		0.782		0.325		0.003	
df	1.000		1.000		1.000		1.000	
	0.026	acceptable fit	0.377	good fit	0.569	good fit	0.953	good fit
chisq/df	4.987	unacceptable fit	0.782	good fit	0.325	good fit	0.003	good fit
rmsea	0.254	unacceptable fit	0.000	good fit	0.000	good fit	0.000	good fit
rmsea_lower	0.071		0.000		0.000		0.000	
rmsea_upper	0.492		0.139		0.120		0.000	
srmr	0.038	good fit	0.003	good fit	0.002	good fit	0.000	good fit
nnfi	0.585	unacceptable fit	1.004	unacceptable fit	1.013	unacceptable fit	1.022	unacceptable fit
cfi	0.972	good fit	1.000	good fit	1.000	good fit	1.000	good fit

chisq, chi squared; df, degrees of freedom

311: Indirect effect of social isolation on hippocampal volume via chronic stress

411a: Indirect effect of social isolation on executive functions via hippocampal volume

411b: Indirect effect of social isolation on memory via hippocampal volume

411c: Indirect effect of social isolation on processing speed via hippocampal volume

Supplement 5

Fit indices of mediation analyses of model 2

fit index	312	ok?	412a	ok?	412b	ok?	412c	ok?
chisq	10.785		0.024		0.790		0.307	
df	5.000		1.000		1.000		1.000	
	0.056	good fit	0.876	good fit	0.374	good fit	0.579	good fit
chisq/df	2.157	acceptable fit	0.024	good fit	0.790	good fit	0.307	good fit
rmsea	0.137	unacceptable fit	0.000	good fit	0.000	good fit	0.000	good fit
rmsea_lower	0.000		0.000		0.000		0.000	
rmsea_upper	0.250		0.075		0.141		0.121	
srmr	0.032	good fit	0.001	good fit	0.002	good fit	0.001	good fit
nnfi	0.859	unacceptable fit	1.017	unacceptable fit	1.005	unacceptable fit	1.016	unacceptable fit
cfi	0.972	good fit	1.000	good fit	1.000	good fit	1.000	good fit

chisq, chi squared; df, degrees of freedom

312: Indirect effect of social isolation on hippocampal volume via chronic stress

412a: Indirect effect of social isolation on executive functions via hippocampal volume

412b: Indirect effect of social isolation on memory via hippocampal volume

412c: Indirect effect of social isolation on processing speed via hippocampal volume

Supplement 6

Adjusted regression coefficients and measures of significance of models without interaction terms

dv	Model	Predictor	Estimate	95% CI	p-value	FDR	BF
Hippo-campal Volume	1	LSNS_base	-5.500	-9.122, -1.878	0.0015	0.0044	14.61
		LSNS_change	-4.894	-8.492, -1.29	0.0039	0.0095	2.9
		age_base	-25.755	-28.582, -22.929			
		age_change	-27.383	-29.659, -25.115			
		gender	-48.683	-85.261, -12.107			
	2	LSNS_base	-5.672	-9.503, -1.84	0.0019	0.0075	19.51
		LSNS_change	-4.928	-8.741, -1.107	0.0058	0.0174	3.31
		age_base	-23.879	-26.9, -20.858			
		age_change	-27.725	-30.141, -25.32			
		gender	-47.733	-85.365, -10.105			
		BMI	18.831	-0.946, 38.609			
		CESD	13.369	-5.716, 32.455			
		diabetes	-103.777	-155.724, -51.827			
		education	-85.695	-147.143, -24.244			
hypertension	-29.051	-69.373, 11.27					
Executive Functions	1	LSNS_base	-0.026	-0.035, -0.017	8.4e-09	1.0e-07	1.5e+06
		LSNS_change	0.003	-0.011, 0.018	0.6787	0.787	0.08
		age_base	-0.020	-0.027, -0.013			
		age_change	-0.053	-0.063, -0.042			
		gender	-0.074	-0.166, 0.017			
	2	LSNS_base	-0.015	-0.025, -0.006	8e-04	0.0046	43.65
		LSNS_change	0.006	-0.009, 0.021	0.7842	0.8555	0.07
		age_base	-0.014	-0.022, -0.007			
		age_change	-0.054	-0.065, -0.043			
		gender	-0.121	-0.214, -0.028			
		BMI	-0.079	-0.128, -0.031			
		CESD	-0.137	-0.183, -0.09			
		diabetes	-0.073	-0.201, 0.054			
		education	-0.351	-0.505, -0.196			
hypertension	-0.078	-0.177, 0.021					

	LSNS_base	-0.014	-0.022, -0.006	5e-04	0.002	49.05
	LSNS_change	-0.013	-0.026, 0	0.0262	0.0449	1.12
Memory	1 age_base	-0.036	-0.042, -0.029			
	age_change	-0.018	-0.027, -0.009			
	gender	-0.381	-0.465, -0.298			
	LSNS_base	-0.008	-0.016, 0.001	0.0452	0.0775	1.25
	LSNS_change	-0.009	-0.023, 0.005	0.1046	0.1569	0.48
	age_base	-0.033	-0.04, -0.026			
	age_change	-0.017	-0.027, -0.008			
	gender	-0.424	-0.51, -0.338			
	2 BMI	-0.030	-0.076, 0.015			
	CESD	-0.117	-0.16, -0.073			
diabetes	-0.045	-0.162, 0.072				
education	-0.166	-0.306, -0.026				
hypertension	0.025	-0.066, 0.116				
Processing Speed	LSNS_base	-0.018	-0.026, -0.011	1.7e-06	1.0e-05	9.4e+03
	LSNS_change	-0.008	-0.021, 0.005	0.1087	0.163	0.39
	1 age_base	-0.038	-0.044, -0.032			
	age_change	-0.033	-0.043, -0.024			
	gender	-0.112	-0.188, -0.035			
	LSNS_base	-0.018	-0.026, -0.01	9.6e-06	1e-04	2.5e+03
	LSNS_change	-0.012	-0.025, 0.001	0.038	0.076	1.33
	age_base	-0.036	-0.042, -0.029			
	age_change	-0.031	-0.041, -0.022			
	gender	-0.135	-0.214, -0.055			
2 BMI	-0.025	-0.066, 0.016				
CESD	-0.024	-0.063, 0.016				
diabetes	0.022	-0.086, 0.131				
education	-0.161	-0.29, -0.031				
hypertension	-0.048	-0.132, 0.036				

p<0.05, BF>3

p<0.01, BF>10

p<0.001, BF>30

p<0.0001, BF>100

dv, dependent variable; CI, confidence interval; FDR, p-values after FDR-correction; BF, Bayes Factor in favour of alternative hypothesis; LSNS_base, baseline Lubben Social Network Score; LSNS_change, change in Lubben Social Network Score; CESD, Center for Epidemiological Studies-Depression

full model1: dv~LSNS_base+LSNS_change+age_base+age_change+gender

full model2: model1 + hypertension+diabetes+education+BMI+CESD

The unit of effect sizes on hippocampal volume and cognitive functions are mm³/point on the LSNS and standard deviation/point on the LSNS, respectively

Supplement 7

Adjusted regression coefficients and measures of significance of models with interaction term of baseline social isolation with change in age

dv	Model	Predictor	Estimate	95% CI	p-value	FDR	BF
Hippo-campal Volume	1	LSNS_base*age_change	-0.556	-1.099, -0.014	0.0223	0.0446	0.52
		LSNS_base	-5.033	-8.682, -1.383			
		LSNS_change	-6.630	-10.591, -2.665			
		age_base	-25.728	-28.554, -22.902			
		age_change	-19.876	-27.531, -12.217			
		gender	-48.216	-84.786, -11.649			
	2	LSNS_base*age_change	-0.538	-1.107, 0.03	0.0318	0.0760	0.63
		LSNS_base	-5.211	-9.072, -1.35			
		LSNS_change	-6.541	-10.702, -2.374			
		age_base	-23.854	-26.874, -20.834			
		age_change	-20.416	-28.492, -12.334			
		gender	-47.198	-84.822, -9.579			
		BMI	18.804	-0.965, 38.576			
		CESD	13.639	-5.442, 32.721			
Executive Functions	1	LSNS_base*age_change	0.001	-0.001, 0.003	0.7946	0.7946	0.06
		LSNS_base	-0.028	-0.037, -0.018			
		LSNS_change	0.006	-0.01, 0.021			
		age_base	-0.020	-0.027, -0.013			
		age_change	-0.066	-0.098, -0.033			
		gender	-0.075	-0.166, 0.017			
	2	LSNS_base*age_change	0.002	-0.001, 0.004	0.9062	0.9062	0.07
		LSNS_base	-0.018	-0.028, -0.008			
		LSNS_change	0.010	-0.006, 0.026			
		age_base	-0.014	-0.022, -0.007			
		age_change	-0.076	-0.111, -0.041			
		gender	-0.122	-0.215, -0.029			
		BMI	-0.079	-0.127, -0.03			
		CESD	-0.137	-0.184, -0.091			
	diabetes	-0.075	-0.203, 0.053				
	education	-0.352	-0.507, -0.197				
	hypertension	-0.080	-0.179, 0.018				

		LSNS_base*age_change	0.001	-0.001, 0.003	0.7214	0.7870	0.06
		LSNS_base	-0.015	-0.024, -0.006			
		LSNS_change	-0.011	-0.026, 0.003			
	1	age_base	-0.036	-0.042, -0.029			
		age_change	-0.027	-0.057, 0.004			
		gender	-0.382	-0.465, -0.298			
		LSNS_base*age_change	0.001	-0.001, 0.003	0.7451	0.8555	0.08
		LSNS_base	-0.009	-0.018, 0.001			
		LSNS_change	-0.007	-0.022, 0.008			
		age_base	-0.033	-0.04, -0.026			
		age_change	-0.028	-0.059, 0.004			
	2	gender	-0.425	-0.51, -0.339			
		BMI	-0.030	-0.076, 0.015			
		CESD	-0.117	-0.16, -0.074			
		diabetes	-0.046	-0.163, 0.071			
		education	-0.167	-0.307, -0.027			
		hypertension	0.024	-0.067, 0.116			
		LSNS_base*age_change	-0.001	-0.003, 0.001	0.1700	0.2266	0.25
		LSNS_base	-0.017	-0.025, -0.008			
		LSNS_change	-0.011	-0.025, 0.003			
	1	age_base	-0.038	-0.044, -0.032			
		age_change	-0.019	-0.05, 0.011			
		gender	-0.111	-0.187, -0.035			
		LSNS_base*age_change	-0.001	-0.003, 0.001	0.2411	0.3215	0.22
		LSNS_base	-0.017	-0.025, -0.008			
		LSNS_change	-0.014	-0.028, 0			
		age_base	-0.036	-0.042, -0.029			
		age_change	-0.021	-0.052, 0.011			
	2	gender	-0.134	-0.213, -0.055			
		BMI	-0.025	-0.066, 0.016			
		CESD	-0.023	-0.063, 0.016			
		diabetes	0.023	-0.085, 0.132			
		education	-0.160	-0.29, -0.031			
		hypertension	-0.047	-0.131, 0.037			

p<0.05, BF>3

p<0.01, BF>10

p<0.001, BF>30

p<0.0001, BF>100

dv, dependent variable; CI, confidence interval; FDR, p-values after FDR-correction; BF, Bayes Factor in favour of alternative hypothesis; LSNS_base, baseline Lubben Social Network Score; LSNS_change, change in Lubben Social Network Score; CESD, Center for Epidemiological Studies-Depression

full model1: dv~LSNS_base+LSNS_change+age_base+age_change+gender

full model2: model1 + hypertension+diabetes+education+BMI+CESD

Supplement 8

Adjusted regression coefficients and measures of significance of models with interaction term of baseline social isolation with change in social isolation

dv	Model	Predictor	Estimate	95% CI	p-value	BF
Hippo- campal Volume	1	LSNS_base*LSNS_change	0.11	-0.61, 0.82	0.6146	0.03
		LSNS_base	-5.50	-9.12, -1.88		
		LSNS_change	-6.30	-16.43, 3.82		
		age_base	-25.75	-28.58, -22.93		
		age_change	-27.25	-29.69, -24.82		
		gender	-48.66	-85.24, -12.09		
	2	LSNS_base*LSNS_change	0.13	-0.62, 0.88	0.6335	0.06
		LSNS_base	-5.67	-9.5, -1.84		
		LSNS_change	-6.67	-17.4, 4.05		
		age_base	-23.88	-26.9, -20.86		
		age_change	-27.57	-30.14, -25.01		
		gender	-47.73	-85.36, -10.1		
		BMI	18.85	-0.92, 38.63		
		CESD	13.34	-5.74, 32.43		
		diabetes	-103.63	-155.58, -51.68		
		education	-85.72	-147.17, -24.27		
		hypertension	-29.01	-69.34, 11.3		

dv, dependent variable; CI, confidence interval; BF, Bayes Factor in favour of alternative hypothesis; LSNS_base, baseline Lubben Social Network Score; LSNS_change, change in Lubben Social Network Score; CESD, Center for Epidemiological Studies-Depression

full model1: $dv \sim LSNS_base + LSNS_change + age_base + age_change + gender$

full model2: $model1 + hypertension + diabetes + education + BMI + CESD$

Supplement 9

Indirect effects of social isolation on hippocampal volume and cognitive functions

Mediator	dv	Model	Estimate	SE	z-value	p-value	n
TICS	Hippo-campal Volume	1	0.0291	0.74	0.04	0.52	62
		2	-0.2059	1.09	-0.19	0.43	62
Hippo-campal Volume	Executive Functions	1	-0.0008	0.00	-0.66	0.26	331
		2	-0.0011	0.00	-0.81	0.21	323
	Memory	1	-0.0008	0.00	-0.69	0.24	322
		2	-0.0014	0.00	-0.92	0.18	313
	Processing Speed	1	-0.0001	0.00	-0.25	0.40	330
		2	-0.0001	0.00	-0.16	0.43	322

dv, dependent variable; SE, standard error; n, number of observations; TICS, Trierer Inventar zum chronischen Stress (stress questionnaire)

model1: corrected for baseline age, change in age and gender

model2: model1 + hypertension+diabetes+education+BMI+CESD

Supplement 10

Adjusted regression coefficients and measures of significance

Models adjusting for the effect of lockdown measures

dv	Model	Predictor	Estimate	95% CI	p-value	FDR	BF
Hippo- campal Volume	1	LSNS_base	-5.5	-9.1, -1.9	0.0014	0.0042	18.65
		LSNS_change	-5.4	-9, -1.8	0.0017	0.0042	7.6
	1	age_base	-25.7	-28.6, -22.9			
		age_change	-25.5	-28.3, -22.7			
	2	pandemic	-38.5	-71.2, -5.8			
		LSNS_base	-5.7	-9.5, -1.9	0.0018	0.0073	20.97
	2	LSNS_change	-5.5	-9.3, -1.7	0.0024	0.0073	6.8
		2	age_base	-23.9	-26.9, -20.8		
	2		age_change	-25.8	-28.8, -22.9		
		2	pandemic	-38.8	-73.5, -3.8		
p<0.05, BF>3			p<0.01, BF>10		p<0.001, BF>30		p<0.0001, BF>100

dv, dependent variable; CI, confidence interval; FDR, p-values after FDR-correction; BF, Bayes Factor in favour of alternative hypothesis; LSNS_base, baseline Lubben Social Network Score; LSNS_change, change in Lubben Social Network Score; CESD, Center for Epidemiological Studies-Depression; pandemic, 0/1 answered LSNS before/after beginning of 1st SARS-CoV-2 lockdown in Germany

full model1: dv~LSNS_base+LSNS_change+age_base+age_change+gender+pandemic

full model2: model1 + hypertension+diabetes+education+BMI+CESD

The effect sizes hardly change when including whether the LSNS was filled out after the begin of lockdown measures in the model. The effect of this control variable itself tends to be associated with smaller hippocampal volume but the confidence interval is very broad.

Supplement 11

Adjusted regression coefficients and measures of significance

Models adjusting for the effect of lockdown measures

dv	Model	Predictor	Estimate	95% CI	p-value	FDR	BF
Executive Functions	1	LSNS_base	-0.026	-0.035, -0.017	7.7e-09	9.2e-08	1.7e+06
		LSNS_change	0.005	-0.01, 0.019	0.733	0.7911	0.08
		age_base	-0.020	-0.027, -0.013			
		age_change	-0.060	-0.073, -0.048			
		pandemic	0.133	0.004, 0.262			
	2	LSNS_base	-0.015	-0.025, -0.006	8e-04	0.0046	36.51
		LSNS_change	0.007	-0.008, 0.022	0.8314	0.9067	0.09
		age_base	-0.014	-0.022, -0.007			
		age_change	-0.061	-0.074, -0.048			
		pandemic	0.136	0.001, 0.27			
Memory	1	LSNS_base	-0.014	-0.022, -0.006	5e-04	0.0021	49.92
		LSNS_change	-0.014	-0.028, -0.001	0.0159	0.0272	1.89
		age_base	-0.036	-0.042, -0.029			
		age_change	-0.009	-0.02, 0.002			
		pandemic	-0.170	-0.29, -0.05			
	2	LSNS_base	-0.008	-0.017, 0.001	0.0444	0.0761	1.33
		LSNS_change	-0.010	-0.024, 0.003	0.0698	0.1047	0.85
		age_base	-0.033	-0.04, -0.026			
		age_change	-0.010	-0.021, 0.002			
		pandemic	-0.158	-0.283, -0.031			
Processing Speed	1	LSNS_base	-0.018	-0.026, -0.011	1.7e-06	1.0e-05	9.7e+03
		LSNS_change	-0.008	-0.021, 0.005	0.1055	0.1582	0.42
		age_base	-0.038	-0.044, -0.032			
		age_change	-0.032	-0.044, -0.021			
		pandemic	-0.020	-0.136, 0.097			
	2	LSNS_base	-0.018	-0.026, -0.01	9.6e-06	1e-04	2.3e+03
		LSNS_change	-0.012	-0.025, 0.001	0.0366	0.0732	1.49
		age_base	-0.036	-0.042, -0.029			
		age_change	-0.030	-0.042, -0.018			
		pandemic	-0.020	-0.14, 0.1			

p<0.05, BF>3

p<0.01, BF>10

p<0.001, BF>30

p<0.0001, BF>100

dv, dependent variable; CI, confidence interval; FDR, p-values after FDR-correction; BF, Bayes Factor in favour of alternative hypothesis; LSNS_base, baseline Lubben Social Network Score; LSNS_change, change in Lubben Social Network Score; CESD, Center for Epidemiological Studies-Depression; pandemic, 0/1 answered LSNS before/after beginning of 1st SARS-CoV-2 lockdown in Germany

full model1: dv~LSNS_base+LSNS_change+age_base+age_change+gender+pandemic

full model2: model1 + hypertension+diabetes+education+BMI+CESD

The effect sizes hardly change when including whether the LSNS was filled out after the begin of lockdown measures in the model. The effect of this control variable itself is inconsistent between the different models.

Supplement 12

Adjusted regression coefficients and measures of significance

Models based on datasets with reduced exclusion criteria

dv	Model	Predictor	Estimate	95% CI	p-value	FDR	BF
Hippo- campal Volume	1	LSNS_base	-3.9	-7.3, -0.5	0.013	0.0222	2.39
		LSNS_change	-5.5	-8.5, -2.4	2e-04	7e-04	32.58
		age_base	-27.3	-29.9, -24.6			
		age_change	-28.6	-30.6, -26.5			
	2	LSNS_base	-3.2	-6.8, 0.4	0.0399	0.0684	0.97
		LSNS_change	-5.7	-9, -2.5	3e-04	0.0017	28.41
		age_base	-25.5	-28.4, -22.7			
		age_change	-29.0	-31.1, -26.8			

p<0.05, BF>3

p<0.01, BF>10

p<0.001, BF>30

p<0.0001, BF>100

dv, dependent variable; CI, confidence interval; FDR, p-values after FDR-correction; BF, Bayes Factor in favour of alternative hypothesis; LSNS_base, baseline Lubben Social Network Score; LSNS_change, change in Lubben Social Network Score; CESD, Center for Epidemiological Studies-Depression

full model1: dv~LSNS_base+LSNS_change+age_base+age_change+gender

full model2: model1 + hypertension+diabetes+education+BMI+CESD

Participants were not excluded for intake of cancer or centrally active medication and cognitive impairment

When applying less exclusion criteria, no major changes occur. For hippocampal volume baseline social isolation becomes deemphasized while the absolute effect size for change in social isolation becomes larger.

Supplement 13

Adjusted regression coefficients and measures of significance

Models based on datasets with reduced exclusion criteria

dv	Model	Predictor	Estimate	95% CI	p-value	FDR	BF
Executive Functions	1	LSNS_base	-0.030	-0.038, -0.022	5.1e-13	6.1e-12	1.6e+10
		LSNS_change	-0.009	-0.021, 0.003	0.0759	0.1138	0.5
		age_base	-0.017	-0.024, -0.011			
		age_change	-0.051	-0.06, -0.042			
	2	LSNS_base	-0.019	-0.028, -0.011	4.5e-06	5.4e-05	4.6e+03
		LSNS_change	-0.005	-0.018, 0.008	0.2223	0.3335	0.27
		age_base	-0.011	-0.018, -0.005			
		age_change	-0.052	-0.062, -0.043			
Memory	1	LSNS_base	-0.017	-0.025, -0.009	2.6e-05	1e-04	745.27
		LSNS_change	-0.015	-0.027, -0.003	0.0079	0.0158	3.1
		age_base	-0.041	-0.048, -0.033			
		age_change	-0.024	-0.032, -0.015			
	2	LSNS_base	-0.009	-0.018, -0.001	0.0164	0.0328	2.91
		LSNS_change	-0.014	-0.026, -0.001	0.0143	0.0328	2.49
		age_base	-0.038	-0.045, -0.03			
		age_change	-0.025	-0.034, -0.016			
Processing Speed	1	LSNS_base	-0.015	-0.022, -0.008	6.1e-06	3.7e-05	2.6e+03
		LSNS_change	-0.016	-0.026, -0.005	0.0022	0.0053	9.29
		age_base	-0.038	-0.043, -0.033			
		age_change	-0.035	-0.043, -0.026			
	2	LSNS_base	-0.012	-0.019, -0.005	5e-04	0.002	58.77
		LSNS_change	-0.017	-0.028, -0.006	0.0012	0.0037	21.76
		age_base	-0.035	-0.04, -0.029			
		age_change	-0.033	-0.041, -0.025			
p<0.05, BF>3		p<0.01, BF>10		p<0.001, BF>30		p<0.0001, BF>100	

dv, dependent variable; CI, confidence interval; FDR, p-values after FDR-correction; BF, Bayes Factor in favour of alternative hypothesis; LSNS_base, baseline Lubben Social Network Score; LSNS_change, change in Lubben Social Network Score; CESD, Center for Epidemiological Studies-Depression

full model1: dv~LSNS_base+LSNS_change+age_base+age_change+gender

full model2: model1 + hypertension+diabetes+education+BMI+CESD

Participants were not excluded for intake of cancer or centrally active medication and cognitive impairment

When applying less exclusion criteria, the direction and magnitude of effect sizes tends to stay the same. The direction of change in social isolation becomes negative but is still small. Most significances are more pronounced. Given the larger sample size, this is to be expected.

Supplement 14

Adjusted regression coefficients and measures of significance

Models only including participants with two timepoints

dv	Model	Predictor	Estimate	95% CI	p-value	FDR	BF
Hippo- campal Volume	1	mean LSNS	-6.9	-11.3, -2.6	9e-04	0.0036	26.01
		LSNS within	-4.7	-8.3, -1.1	0.0054	0.0161	1.92
		mean age	-26.1	-29.4, -22.7			
		age within	-26.5	-28.8, -24.2			
	2	mean LSNS	-6.7	-11.2, -2.1	0.0021	0.0101	17.76
		LSNS within	-4.6	-8.4, -0.8	0.009	0.027	1.87
		mean age	-24.6	-28.1, -21			
		age within	-26.8	-29.2, -24.4			

p<0.05, BF>3

p<0.01, BF>10

p<0.001, BF>30

p<0.0001, BF>100

dv, dependent variable; CI, confidence interval; FDR, p-values after FDR-correction; BF, Bayes Factor in favour of alternative hypothesis; mean LSNS, subject's mean Lubben Social Network Score; LSNS within, within subject variation in Lubben Social Network Score; mean age, subject's mean age; age within, within subject variation in age; CESD, Center for Epidemiological Studies-Depression

full model1: dv~LSNS_base+LSNS_change+age_base+age_change+gender

full model2: model1 + hypertension+diabetes+education+BMI+CESD

In this sensitivity analysis only participants with two timepoints were included and standard mean and within scores rather than baseline and change scores were calculated. In terms of effect size and direction our original model is corroborated. Smaller measures of significance in this smaller sample were expectable.

Supplement 15

Adjusted regression coefficients and measures of significance

Models only including participants with two timepoints

dv	Model	Predictor	Estimate	95% CI	p-value	FDR	BF
Executive Functions	1	mean LSNS	-0.027	-0.037, -0.016	5.9e-07	7.1e-06	2.7e+04
		LSNS within	0.005	-0.011, 0.021	0.7316	0.7607	0.08
		mean age	-0.014	-0.023, -0.006			
		age within	-0.055	-0.066, -0.045			
	2	mean LSNS	-0.016	-0.027, -0.005	0.0025	0.0101	16.1
		LSNS within	0.005	-0.012, 0.021	0.7176	0.7829	0.11
		mean age	-0.008	-0.016, 0.001			
		age within	-0.055	-0.065, -0.044			
Memory	1	mean LSNS	-0.010	-0.019, 0	0.0225	0.045	2.02
		LSNS within	-0.010	-0.024, 0.004	0.0874	0.1498	0.43
		mean age	-0.031	-0.039, -0.024			
		age within	-0.018	-0.027, -0.009			
	2	mean LSNS	-0.006	-0.016, 0.004	0.1243	0.2131	0.66
		LSNS within	-0.006	-0.021, 0.008	0.2046	0.307	0.3
		mean age	-0.027	-0.035, -0.02			
		age within	-0.016	-0.025, -0.006			
Processing Speed	1	mean LSNS	-0.015	-0.024, -0.006	4e-04	0.0027	58.1
		LSNS within	-0.006	-0.02, 0.009	0.2218	0.3305	0.2
		mean age	-0.039	-0.046, -0.032			
		age within	-0.033	-0.043, -0.023			
	2	mean LSNS	-0.014	-0.024, -0.005	0.0017	0.0101	21.84
		LSNS within	-0.011	-0.026, 0.004	0.0721	0.1441	0.66
		mean age	-0.038	-0.045, -0.031			
		age within	-0.031	-0.041, -0.021			
		p<0.05, BF>3	p<0.01, BF>10	p<0.001, BF>30	p<0.0001, BF>100		

dv, dependent variable; CI, confidence interval; FDR, p-values after FDR-correction; BF, Bayes Factor in favour of alternative hypothesis; LSNS_base, mean LSNS, subject's mean Lubben Social Network Score; LSNS_within, within subject variation in Lubben Social Network Score; mean age, subject's mean age; age_within, within subject variation in age; CESD, Center for Epidemiological Studies-Depression

full model1: dv~LSNS_base+LSNS_change+age_base+age_change+gender

full model2: model1 + hypertension+diabetes+education+BMI+CESD

In this sensitivity analysis only participants with two timepoints were included and standard mean and within scores rather than baseline and change scores were calculated. As for hippocampal volume, this sensitivity analysis corroborates our original model.

Supplement 16

Adjusted regression coefficients and measures of significance of models stratified by gender

dv	Model	gender	Predictor	Estimate	95% CI	p-value	FDR
Hippo-campal Volume	1	female	LSNS_base	-7.265	-12.546, -1.984	0.0036	0.0142
			LSNS_change	-3.826	-8.389, 0.75	0.0503	0.1006
			LSNS_base*age_change	-0.311	-0.992, 0.37	0.1847	0.2463
			LSNS_base*LSNS_change	-0.026	-0.865, 0.812	0.4755	
	1	male	LSNS_base	-4.418	-9.407, 0.572	0.0414	0.0827
			LSNS_change	-5.821	-11.462, -0.17	0.0218	0.0655
			LSNS_base*age_change	-0.793	-1.656, 0.066	0.0356	0.0827
			LSNS_base*LSNS_change	0.426	-0.831, 1.696	0.7466	
	2	female	LSNS_base	-9.402	-15.042, -3.762	6e-04	0.0068
			LSNS_change	-3.452	-8.28, 1.395	0.0807	0.1614
			LSNS_base*age_change	-0.255	-0.971, 0.462	0.2422	0.3229
			LSNS_base*LSNS_change	0.027	-0.842, 0.895	0.5248	
	2	male	LSNS_base	-3.046	-8.299, 2.207	0.1277	0.2554
			LSNS_change	-6.344	-12.289, -0.39	0.0185	0.1111
			LSNS_base*age_change	-0.796	-1.692, 0.095	0.0403	0.1209
			LSNS_base*LSNS_change	0.448	-0.876, 1.783	0.7464	
Executive Functions	1	female	LSNS_base	-0.032	-0.045, -0.018	1.6e-06	1.9e-05
			LSNS_change	-0.006	-0.026, 0.014	0.2797	0.3357
			LSNS_base*age_change	0.001	-0.002, 0.004	0.7135	0.7135
	1	male	LSNS_base	-0.022	-0.034, -0.009	4e-04	0.0022
			LSNS_change	0.013	-0.007, 0.033	0.9021	0.9021
			LSNS_base*age_change	0.001	-0.002, 0.005	0.8056	0.8789
	2	female	LSNS_base	-0.020	-0.034, -0.006	0.0032	0.019
			LSNS_change	0.001	-0.02, 0.022	0.547	0.6564
			LSNS_base*age_change	0.002	-0.002, 0.005	0.8642	0.8642
	2	male	LSNS_base	-0.012	-0.025, 0	0.0293	0.1173
LSNS_change			0.012	-0.009, 0.033	0.8653	0.8653	
LSNS_base*age_change			0.002	-0.002, 0.005	0.8482	0.8653	

Memory	1 female	LSNS_base	-0.011	-0.023, 0.001	0.0345	0.0827	
		LSNS_change	-0.017	-0.034, -0.001	0.0218	0.0655	
		LSNS_base*age_change	0.000	-0.003, 0.003	0.5141	0.5609	
	1 male	LSNS_base	-0.016	-0.028, -0.004	0.0035	0.0141	
		LSNS_change	-0.007	-0.028, 0.013	0.2454	0.4081	
		LSNS_base*age_change	0.001	-0.002, 0.005	0.7892	0.8789	
	2 female	LSNS_base	-0.004	-0.017, 0.008	0.2417	0.3229	
		LSNS_change	-0.015	-0.032, 0.003	0.0494	0.1185	
		LSNS_base*age_change	0.000	-0.002, 0.003	0.612	0.6677	
		2 male	LSNS_base	-0.010	-0.022, 0.003	0.0644	0.1544
			LSNS_change	-0.002	-0.023, 0.02	0.4446	0.5928
			LSNS_base*age_change	0.001	-0.002, 0.004	0.7429	0.8653
Processing Speed	1 female	LSNS_base	-0.017	-0.028, -0.005	0.0028	0.0142	
		LSNS_change	-0.009	-0.026, 0.009	0.1632	0.2448	
		LSNS_base*age_change	-0.002	-0.005, 0.001	0.127	0.2177	
	1 male	LSNS_base	-0.020	-0.03, -0.01	6.6e-05	8e-04	
		LSNS_change	-0.006	-0.025, 0.013	0.2721	0.4081	
		LSNS_base*age_change	0.000	-0.003, 0.003	0.4427	0.5903	
	2 female	LSNS_base	-0.016	-0.029, -0.004	0.0053	0.0211	
		LSNS_change	-0.015	-0.033, 0.002	0.0449	0.1185	
		LSNS_base*age_change	-0.001	-0.004, 0.002	0.1922	0.3229	
	2 male	LSNS_base	-0.018	-0.029, -0.008	4e-04	0.0051	
		LSNS_change	-0.007	-0.028, 0.013	0.2368	0.4059	
		LSNS_base*age_change	0.000	-0.003, 0.003	0.4265	0.5928	

p<0.05

p<0.01

p<0.001

p<0.0001

dv, dependent variable; CI, confidence interval; FDR, p-values after FDR-correction; LSNS_base, baseline Lubben Social Network Score; LSNS_change, change in Lubben Social Network Score; CESD, Center for Epidemiological Studies-Depression

full model1: dv~LSNS_base+LSNS_change+age_base+age_change

full model2: model1 + hypertension+diabetes+education+BMI+CESD

The unit of effect sizes on hippocampal volume and cognitive functions for non-interaction models are mm³/point on the LSNS and standard deviation/point on the LSNS, respectively. For interaction models the unit in the denominator is multiplied by year or point on the LSNS.

Supplement 17

Relevant Regressions of Bivariate Latent Change Score Models

dv	predictor	estimate	se	p-value	q value
Δ HCV	LSNS_base	-0.430	1.715	0.401	0.539
Δ LSNS	HCV_base	-0.001	0.001	0.077	0.172
Δ EF	LSNS_base	-0.015	0.007	0.019	0.075
Δ LSNS	EF_base	-0.279	0.204	0.086	0.172
Δ Memo	LSNS_base	0.002	0.008	0.586	0.586
Δ LSNS	Memo_base	-0.181	0.209	0.192	0.256
Δ PS	LSNS_base	-0.002	0.008	0.404	0.539
Δ LSNS	PS_base	-0.080	0.193	0.340	0.340

p<0.05

dv, dependent variable; se, standard error; _base, baseline score of; Δ , change in; LSNS, Lubben Social Network Score; HCV, hippocampal volume; EF, executive functions; Memo, memory; PS, processing speed

Only baseline social isolation significantly predicts change in executive functions. The p-value of 0.019 does not survive any multiplicity control, though.

Supplement 18

Results of Power Simulation of Bayes Factors

Category	BFA0b > 3 in %	3 >= BFA0b >= 1/3 in %	BFA0b < 1/3 in %	BFA0c > 3 in %	3 >= BFA0c >= 1/3 in %	BFA0c < 1/3 in %	n
overall	44.23	31.41	24.36	28.85	30.45	40.71	312
model 1	45.51	30.13	24.36	30.13	30.13	39.74	156
model 2	42.95	32.69	24.36	27.56	30.77	41.67	156
effect = 0.1	9.62	38.46	51.92	5.77	24.04	70.19	104
effect = 0.2	37.50	44.23	18.27	21.15	39.42	39.42	104
effect = 0.5	85.58	11.54	2.88	59.62	27.88	12.50	104

BFA0b, Sided Bayes factor in favour of the alternative hypothesis of baseline social isolation; BFA0c, Sided Bayes factor in favour of the alternative hypothesis of change in social isolation; n, number of simulations in the category; model 1, model with reduced number of control variables; model 2, model with full number of control variables; effect, effect size per point in the Lubben Social Network Scale in years of baseline age

Percentages of Bayes Factors giving moderate or stronger evidence in favour of the alternative hypothesis (>3), giving anecdotal evidence ($3 \geq \text{BF} \geq 1/3$) and giving moderate or stronger evidence in favour of the null hypothesis ($< 1/3$)

Supplement 19

Results of Power Simulation of Bayes Factors

Adjusted thresholds for a family of 12 tests

Category	BFA0b > 10.75 in %	10.75 >= BFA0b >= 1/3 in %	BFA0b < 1/3 in %	BFA0c > 10.75 in %	10.75 >= BFA0c >= 1/3 in %	BFA0c < 1/3 in %	n
overall	37.18	38.46	24.36	20.83	38.46	40.71	312
model 1	38.46	37.18	24.36	21.79	38.46	39.74	156
model 2	35.90	39.74	24.36	19.87	38.46	41.67	156
effect = 0.1	5.77	42.31	51.92	0.96	28.85	70.19	104
effect = 0.2	24.04	57.69	18.27	14.42	46.15	39.42	104
effect = 0.5	81.73	15.38	2.88	47.12	40.38	12.50	104

BFA0b, Sided Bayes factor in favour of the alternative hypothesis of baseline social isolation; BFA0c, Sided Bayes factor in favour of the alternative hypothesis of change in social isolation; n, number of simulations in the category; model 1, model with reduced number of control variables; model 2, model with full number of control variables; effect, effect size per point in the Lubben Social Network Scale in years of baseline age

Percentages of Bayes Factors giving moderate or stronger evidence in favour of the alternative hypothesis (>10.75), giving anecdotal evidence ($10.75 \geq \text{BF} \geq 1/3$) and giving moderate or stronger evidence in favour of the null hypothesis ($< 1/3$)

Supplement 20

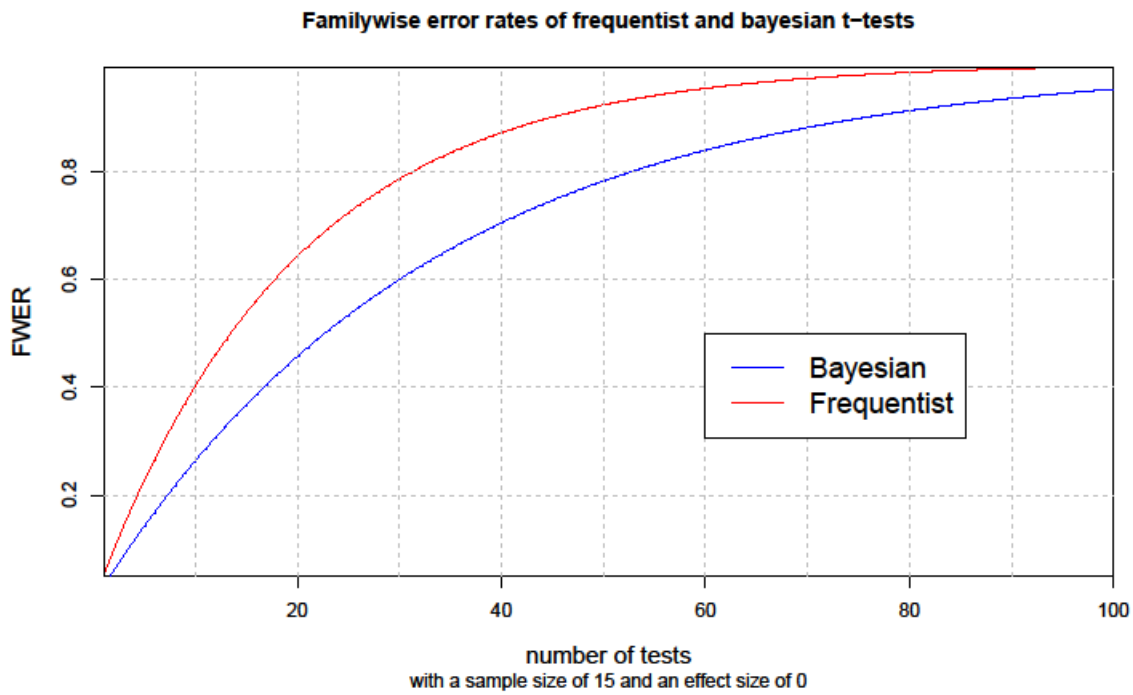

Supplement 21

Histogram of BFs with randomly simulated values for our predictors of interest.

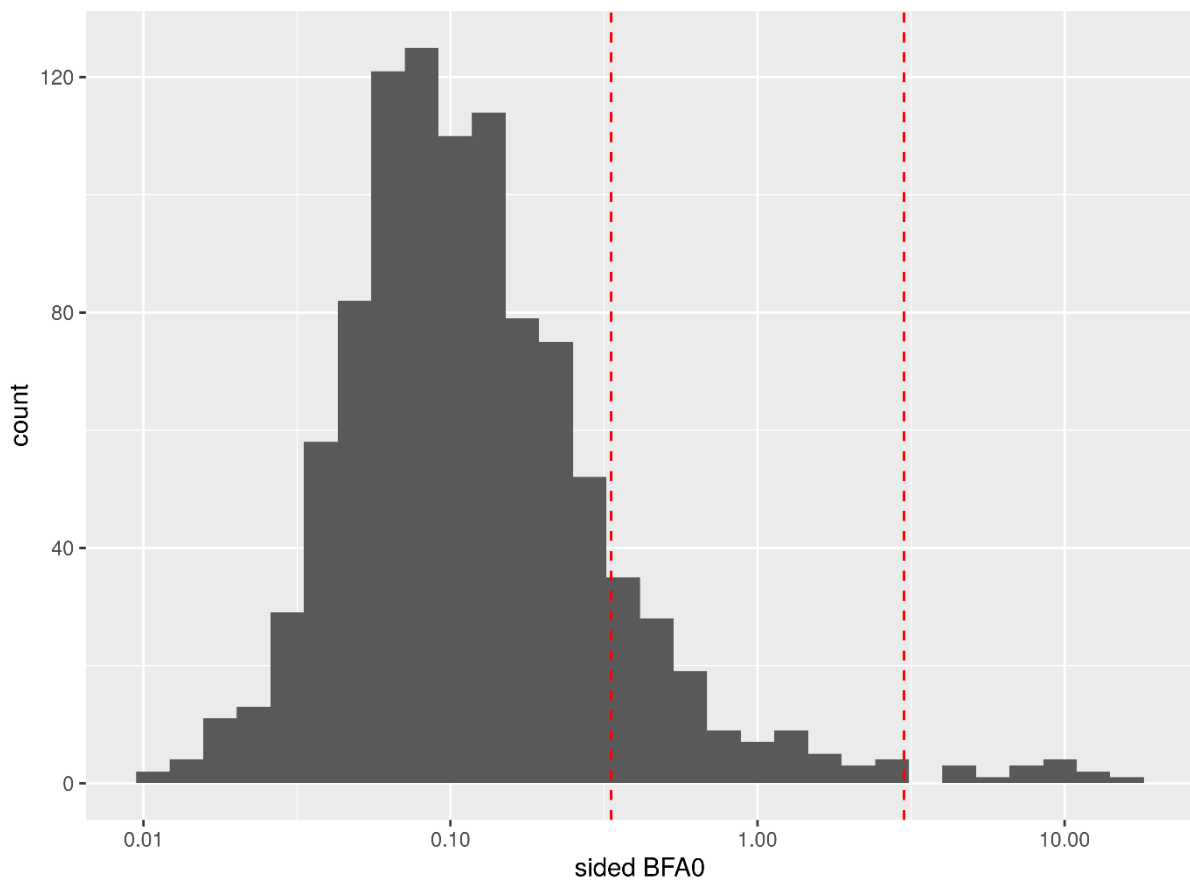

The red lines show the traditional thresholds at $1/3$ and 3 .

Supplement 22

Bayes Factors over the threshold of 3

BFA0	FWER in %	n
15.744	1.18	1
13.634	2.36	2
13.139	3.51	3
10.926	4.66	4
10.632	5.79	5
9.196	6.91	6
8.728	8.02	7
8.510	9.12	8
7.749	10.20	9
7.191	11.28	10
6.081	12.34	11
4.746	13.39	12
4.044	14.42	13
4.003	15.45	14

BFA0, Sided Bayes factor in favour of the alternative hypothesis;
FWER, familywise error rate if the threshold would be set just below
BFA0

In the simulation with randomly simulated values for our predictors of interest, 14 BFs exceeded the standard threshold of three. Given a family size of 12 tests, a threshold of 10.75 would maintain the FWER below 5%.

References

1. Bono C, Ried LD, Kimberlin C, Vogel B. Missing data on the Center for Epidemiologic Studies Depression Scale: a comparison of 4 imputation techniques. *Res Social Adm Pharm.* 2007 Mar;3(1):1–27.
2. Gelman A, Hill J, Yajima M. Why We (Usually) Don't Have to Worry About Multiple Comparisons. *J Res Educ Eff.* 2012 Apr 1;5(2):189–211.
3. Sjölander A, Vansteelandt S. Frequentist versus Bayesian approaches to multiple testing. *Eur J Epidemiol.* 2019;34(9):809–21.
4. Keysers C, Gazzola V, Wagenmakers EJ. Using Bayes factor hypothesis testing in neuroscience to establish evidence of absence. Vol. 23, *Nature Neuroscience*. Nature Research; 2020. p. 788–99.
5. Jong T, Marsman M, Wagenmakers E-J. A Bayesian Approach to the Correction for Multiplicity. 2019.
6. Storey JD. A direct approach to false discovery rates. *J R Stat Soc Ser B (Statistical Methodol.* 2002 Aug 1;64(3):479–98.
7. Mays N, Pope C. Assessing quality in qualitative research. *BMJ.* 2000;320(7226):50–2.
8. Sandelowski M, Barroso J. Finding the findings in qualitative studies. *J Nurs Scholarsh.* 2002;34(3):213–9.
9. Ryan L, Golden A. 'Tick the Box Please': A Reflexive Approach to Doing Quantitative Social Research. *Sociology.* 2006 Dec 1;40(6):1191–200.
10. Nosek BA, Ebersole CR, DeHaven AC, Mellor DT. The preregistration revolution. *Proc Natl Acad Sci.* 2018;115(11):2600–6.
11. Nosek BA, Lakens D. Registered reports: A method to increase the credibility of published results. Vol. 45, *Social Psychology*. 2014. p. 137–41.
12. Krieger N. *Epidemiology and the people's health: Theory and context*. New York, NY, US: Oxford University Press; 2011.
13. Berger R. Now I see it, now I don't: researcher's position and reflexivity in qualitative research. *Qual Res.* 2013 Jan 3;15(2):219–34.
14. Solomon M. *Social Empiricism*. Cambridge, Massachusetts: MIT Press; 2001.
15. Gould SJ. *The mismeasure of man: Revised and expanded*. New York: Norton; 1996.
16. Berkman LF, Kawachi I, Glymour MM. *Social Epidemiology*. Oxford, UK: Oxford University Press; 2015.
17. Krieger N. Got Theory? On the 21st c. CE Rise of Explicit use of Epidemiologic Theories of Disease Distribution: A Review and Ecosocial Analysis. *Curr Epidemiol Reports.* 2014;1(1):45–56.